



► FROM PENTAIR WATER SOLUTIONS

CES-9100TS E-30C SERIES TWIN TANK, TWIN SENSOR WATER SOFTENER

Part Number: EV998065



SYSTEM DESCRIPTION

Water Conditioning with Sensor Monitoring for Commercial and Light Industrial Applications Configured as a Twin Tank System with 3/4" porting.

FEATURES • BENEFITS

- ◆ Hardness removal of up to 35,080 grains per tank
- ◆ Flow rates of up to 7.9 gallons per minute continuous
- ◆ Proactive protection for your valuable equipment investments
- ◆ Maximizes operational efficiency, optimizes salt use
- ◆ Alerts indicating system is unplugged or salt is low
- ◆ Power supply meets Energy Efficiency Class VI standards of United States Department of Energy (DoE) requirements
- ◆ Twin sensor constantly adjusts to changing water conditions
- ◆ Twin tank design ensures soft water is being fed to equipment 24/7, even when one tank regenerates or needs salt replacement
- ◆ Upflow brining for improved treatment capacity
- ◆ NSF certified to Standard 44 for performance and efficiency
- ◆ Corrosion resistant with fiberglass reinforced resin vessels

APPLICATIONS

- ◆ Foodservice
- ◆ Tea Brewing
- ◆ General housekeeping
- ◆ Cold Water Fed Warewashing
- ◆ Water heater scale protection/reduction
- ◆ Reverse Osmosis Pretreatment
- ◆ In-house Laundry - linen & uniform

INSTALLATION TIPS

- ◆ Locate equipment on a smooth, level surface.
- ◆ Maintain an air-gap at the end of the drain line.
- ◆ Secure drain line directly over floor drain or stand pipe.
- ◆ When connecting to a water heater, install a check valve on the soft water piping to prevent hot water back-up.
- ◆ When sweating/installing copper piping, protect the control valve from excessive heat.
- ◆ Check local codes for additional equipment that may be required, such as backflow prevention devices (i.e. RPZ).

CES-9100TS E-30C TWIN TANK, TWIN SENSOR WATER SOFTENER

EV998065

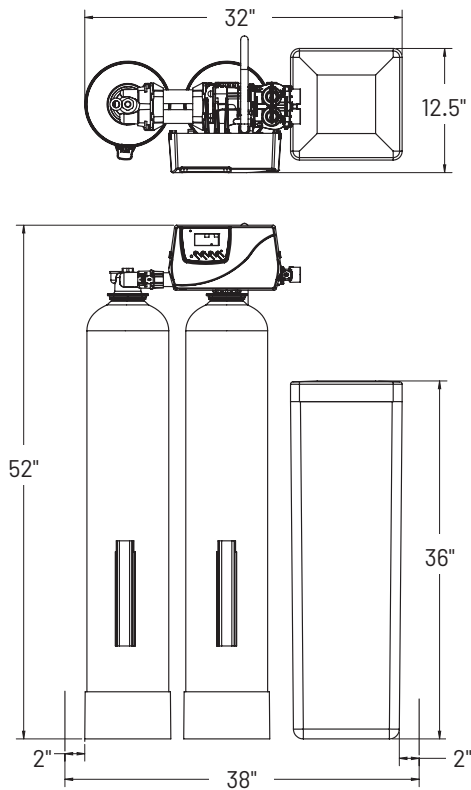

SPECIFICATIONS

System

Overall Dimensions

52" H x 38" W x 12.5" D
(132 cm x 91 cm x 32 cm)

Connections

Inlet Connection: 3/4" FNPT
Outlet Connection: 3/4" FNPT

Operating Pressure

20 - 125 psi (1.4 - 8.6 bar)
non-shock

Water Temperature

34 - 110°F (1.1 - 43.3°C)

Operating Weight

520 lbs (236 kgs)

Shipping Weight

155 lbs (70 kgs)

Electrical Connection

120 VAC/60 HZ/1 Phase, <0.2A

Salt Storage Capacity

125 lbs (57 kgs)

Performance

Service Flow Rate

Minimum: 1 gpm (3.8 lpm)
@ 15 psi (1.0 bar) ΔP
Continuous: 7.9 gpm (30 Lpm)

Rated Capacity

35,080 grains @ 15 lbs (6.8 kg) salt
14,457 grains @ 3.0 lbs (1.4 kg) salt

Efficiency Rating

4,819 grains/lbs salt @ 3.0 lbs
salt setting

For Pentair Everpure Product Warranties visit:
<http://pentair.com/assets/foodservice-warranty>.
To receive a free copy email or call your Pentair
representative using the information provided below.



Tested and Certified by NSF International against
NSF/ANSI Standard 44 for Softener Performance.

Conforms to ≤0.25 weighted average percent lead.



1040 Muirfield Drive | Hanover Park, IL 60133 | 800.942.1153 (US Only) 630.307.3000 Main | cseverpure@pentair.com | foodservice.pentair.com

All indicated Pentair trademarks and logos are property of Pentair. Third party registered and unregistered trademarks and logos are the property of their respective owners.

©2026 Pentair. All rights reserved.

EV9980-65 MY26