

AquaFlame Ultrasonic Humidifier

Owner's Manual



English

**Models:
LP300HUM
(All Colors)**

READ AND SAVE THESE INSTRUCTIONS

Form #LP300HUM
08012023
© 2023 Registered Trademark/ TM Trademark of LivePure LLC.
Manufactured exclusively for LivePure LLC.
All rights reserved.



Table of Contents

At a Glance

Warnings & Know Your Humidifier 2-3

Operating Your Humidifier

Initial Setup 4

Humidifier Operation 5

Maintenance 6-7

Humidifier Assistance

Troubleshooting 8

Technical Support 9

Warranty 10-12

At a Glance

Warnings & Know Your Humidifier

Thank you for purchasing the AquaFlame Ultrasonic Humidifier from LivePure® Company. Please read and save these instructions to receive the maximum benefit and performance from your humidifier.

READ AND SAVE THESE INSTRUCTIONS!

Important Safety Instructions:

Read all instructions before using this humidifier

- This humidifier may not work properly on an uneven surface. ALWAYS place this humidifier on a firm, level, and water resistant surface.
- ALWAYS place the humidifier at least six (6) inches away from walls, heat sources, and electrical appliances such as stoves, radiators, or heaters.
- ALWAYS place the humidifier in an area that is out of the reach of children.
- Before using the humidifier, extend the cord and inspect for any signs of damage. DO NOT use the product if the cord has been damaged.
- Use only the LivePure AC adapter intended for this product, model LP300HUM. Using any other AC adapter can damage the humidifier and may void your warranty. Do not use the power cord supplied with the AC adapter with another instrument.
- Do not disassemble or modify the AC adapter.
- Do not use the AC adapter outdoors or in locations subject to rain, water, heat, fire or sun.
- Never wrap a power cord around an AC adapter or other object. Doing so can stress the cord in ways that can cause the cord to fray, crack, or crimp. This can present a safety hazard.
- Protect power cord and AC adapter from liquids. Do not leave power cord or AC adapter near sinks, tubs, toilets, or on floors that are cleaned with liquid cleaners. Liquids can cause a short circuit.
- Ensure that all power cord connectors are securely and completely plugged into receptacles.
- Do not use any AC adapter that shows corrosion or signs of overheating.
- To prevent possible overheating, do not cover the AC adapter with clothing or other objects when the AC adapter is plugged into an electrical outlet.
- ALWAYS UNPLUG AND EMPTY the humidifier when it is not in operation or while it is being cleaned.
- Use only clean, cool tap water when filling the tank. DO NOT use hot water.
- Never add medication of any type to the water tank.

At a Glance

Warnings & Know Your Humidifier

- You should never leave the unit unattended in a closed room. The room can become saturated and leave condensation on walls and furniture. Always leave a door partially open.
- This device complies with part 18 of the FCC Rules.
- To reduce risk of fire, electric shock, or injury, place the unit and cord where it is not likely to be tipped or bumped.
- Do not overfill the humidifier due to potential risk of electric shock.
- ALWAYS disconnect the product from power source before performing any maintenance or cleaning.

Adaptor Specifications:

Input: 100 - 240V ~ 50/60Hz, 0.8A

Output: 24V DC 1000 mA

Operating Your Humidifier

Initial Setup

Initial Setup:

1. Remove the plastic bag covering from the humidifier.
2. Unravel and straighten the cord before use. Connect the adaptor to the humidifier.
3. Remove the cover from the humidifier base by grasping the tab and removing from humidifier.
4. Fill the unit with clean, cool tap water up to max fill line. Do not fill past max fill line. **Figure 1**
5. Place the cover back on the humidifier.
6. Plug the humidifier into a wall outlet and start the unit.

Figure 1

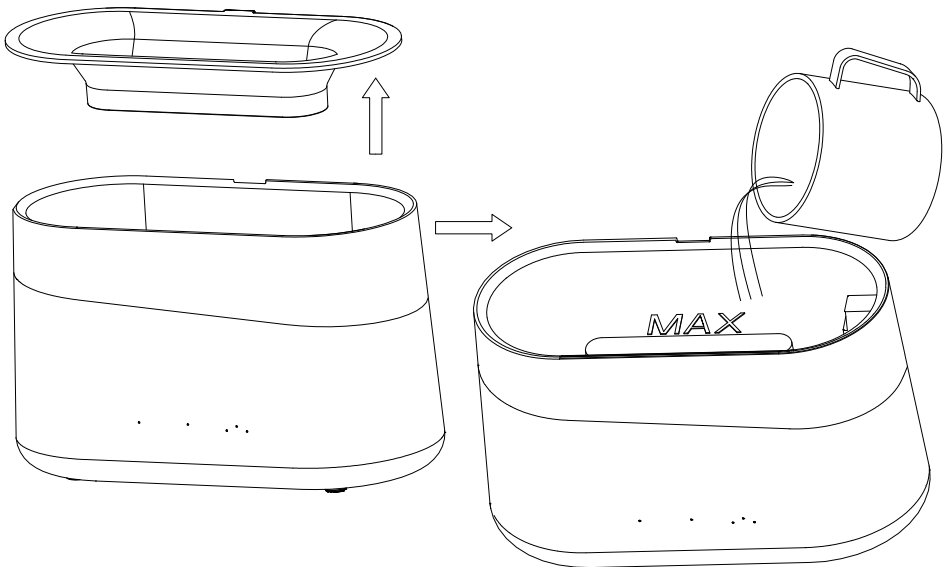

Operating Your Humidifier

Humidifier Operation

Operating the Humidifier:

1. **Power:** Touch the power button once and the humidifier will output mist on low. Accent light will turn on. Touch the power button a second time and the humidifier will output mist on high. Touch the power button a third time to turn off the humidifier. **Figure 2**

2. **Timer:** To set time, press TIMER button. There will be a light next to the selected time. Continue pressing the TIMER button until desired amount of time is selected. Choose from 2, 4, or 8 hour intervals. **Figure 2**

3. **Accent Light:** Accent light will automatically come on and be displayed as blue when humidifier is powered on. To change color of the accent light, continue pressing the ACCENT LIGHT button. Choose from blue, red, orange, green, or pink. Press the ACCENT LIGHT button once more to turn accent light off.

Figure 2

Figure 2

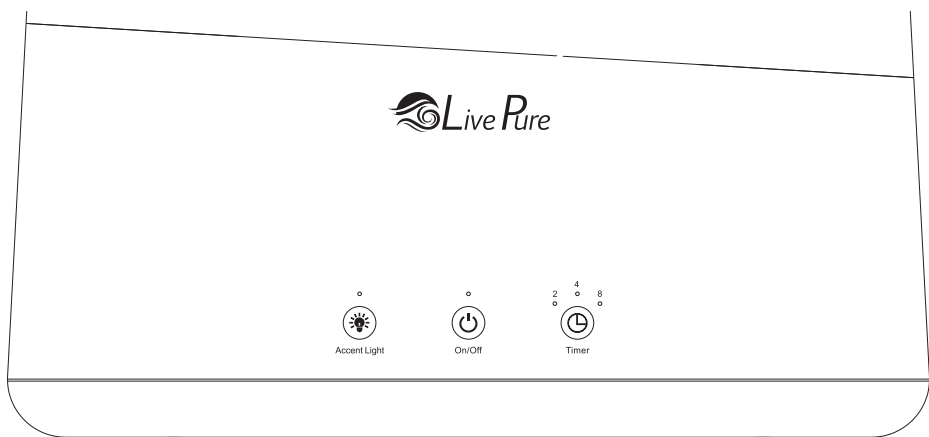

Operating Your Humidifier

Maintenance

Daily Maintenance:

Note: ALWAYS unplug the humidifier from the electrical outlet before cleaning.

1. Turn off the humidifier and unplug it from the wall outlet.
2. Remove the cover by pulling it straight off the humidifier. **Figure 3**
3. Turn the humidifier upside down and drain any water into a sink or tub. Shake the unit gently to remove any remaining water.
4. Rinse the tank thoroughly with water, empty, and wipe with a clean, dry cloth.
5. Wipe the humidifier base with a dry cloth if necessary.
6. Refill the tank as directed under *Initial Set Up* and resume use.

Cleaning the Aroma Port:

Note: It is recommended to clean the aroma port and pad after every essential oil use.

1. Turn off the humidifier and unplug it from the wall outlet.
2. Press in on aroma port to release the tray. **Figure 3**
3. Remove the aroma pad and rinse it out or replace with a new one.
4. Use a soft, damp cloth to clean the inside of the tray.
5. Allow both the tray and the pad to air dry.
6. Insert pad into tray, laying flat, and return tray to humidifier.

Figure 3

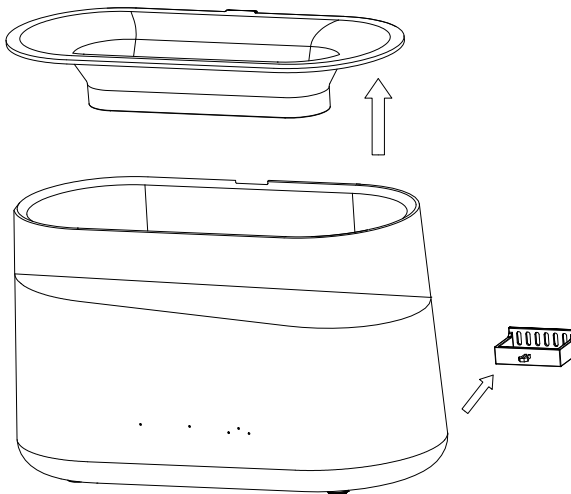

Weekly Maintenance:

1. Turn off the humidifier and unplug it from the wall outlet.
2. Remove the cover by pulling it straight off the humidifier.
3. Turn the humidifier upside down and drain any water into a sink or tub. Shake the unit gently to remove any remaining water.
4. Fill the water tank with a mixture of 1 cup of water and eight (8) ounces of white vinegar. Let the mixture sit in the water tank for 20 minutes before discarding the mixture.
5. Rinse the water tank several times with clean water. Leave the cover off to allow the water tank to dry completely.
6. Wipe the surfaces of the humidifier base with a soft damp cloth.
7. Once all the parts are clean and dry, reassemble the humidifier, refill the water tank, and resume use.

Note: Daily and weekly maintenance is necessary to prevent the growth of bacteria, mold, and fungi.

End of Season Maintenance:

1. Follow the instructions for weekly maintenance before storing the unit.
2. Ensure all parts are completely dry before storing the unit.
3. Store the unit in a cool, dry place.
4. Never store the unit with water in the tank.

LivePure is not liable for any damages of any kind resulting from misuse or improper maintenance. Warranty is only valid when proper maintenance, as stated in this user manual, has been followed, as warranties apply explicitly to manufacturer's defects only.

Humidifier Assistance

Troubleshooting

Problem: Excessive Noise

Solution:

1. Check the humidifier to make sure the cover is properly seated on the base.
2. Check the water tank to make sure there are no bubbles when the water tank is full and running. If there are bubbles, turn the unit off until the bubbling stops. When the bubbling has stopped, set the unit to the desired speed.

Problem: Humidifier not working

Solution:

1. Make sure the power button is not set to "Off"

Problem: Mineral buildup on the water tank or tray

Solution:

1. Refer to the section *Maintenance*.

Problem: Humidity output and water usage decreased

Solution:

1. Check the Power Button to make sure it is set to the desired humidity level and speed.
2. Check the water tank to make sure there are no bubbles when the water tank is full and running. If there are bubbles, turn the unit off until the bubbling stops. When the bubbling has stopped, set the unit to the desired speed.
3. Clean any components that have mineral build-up. Refer to the section *Maintenance*.

Technical Support

If you need any assistance with setup, operation, or parts for your new LivePure® humidifier, please call us. Our technical support staff is ready to help!

USA/Canada: 888-855-5426
Email: info@livepureshop.com

Hours of operation are from 8:00 AM to 6:00 PM ET, Monday through Friday. You may also contact us online at **www.livepureshop.com**.

For all of the latest updates and promotions, follow us on our social media channels:



@LivePureShop



@livepure_shop

Warranty

1 Year Limited Warranty

LivePure®, LLC makes the following limited warranty to the original residential user or consumer purchaser of the **Ultrasonic Humidifier**: If any part of the **Ultrasonic Humidifier** fails during the first (1) year from the date of purchase due to a defect in material or workmanship, we will provide a replacement part free of charge. If no replacement part can be provided, we will replace your **humidifier**.

IF THE ORIGINAL RESIDENTIAL USER OR CONSUMER PURCHASER CEASES TO OWN THE **ULTRASONIC HUMIDIFIER**, THIS WARRANTY AND ANY IMPLIED WARRANTY WHICH THEN REMAINS IN EFFECT, INCLUDING BUT NOT LIMITED TO ANY IMPLIED WARRANTY OF MERCHANTABILITY OR FITNESS FOR A PARTICULAR PURPOSE, ARE VOIDED. THIS WARRANTY IS IN LIEU OF ALL OTHER EXPRESS WARRANTIES. THE DURATION OF ANY IMPLIED WARRANTY, INCLUDING BUT NOT LIMITED TO ANY IMPLIED WARRANTY OF MERCHANTABILITY OR FITNESS FOR A PARTICULAR PURPOSE IS EXPRESSLY LIMITED TO THE PERIOD OF THE EXPRESS WARRANTY SET FORTH ABOVE.

This warranty is voided if your **Ultrasonic Humidifier** is not purchased and used in the USA or Canada.

This warranty excludes and does not cover defects, malfunctions, or failures of the **humidifier** which were caused by repairs by persons not authorized by us, use of parts, or accessories not authorized by us, mishandling, possession, or unreasonable use, including failure to provide reasonable and necessary maintenance. This warranty does not cover **humidifiers** used in commercial applications. There are no express or implied warranties as to commercial purchasers or users.

See next page for more information on what is not covered.

Warranty

1 Year Limited Warranty

What is not covered:

- Units that are sold “as is”, are used, or sold by unauthorized resellers (an unauthorized reseller is defined as any third-party reseller who has no official relationship with Mindful LLC.)
- Shipping or freight charges to return products for warranty service.
- Commercial or non-residential use or use inconsistent with the product instructions and manuals.
- Consumable parts (e.g., light bulbs, batteries, filters, etc.)
- Defects or damage resulting from accident, misuse, abuse, alteration, fire, floods, or acts of God.
- Cosmetic damage (e.g., scratches, dents, chips, and other damage to finishes), unless such damage results from defects in materials and workmanship and is reported within 30 days from date of delivery.
- Units with original, factory installed model numbers removed, altered, or not easily determined.
- Damage resulting from improper packing of products returned for warranty service.
- Replacement parts, repair labor costs and/or replacement of a “failed” **humidifier** operated outside the United States and Canada.
- Mindful LLC will have the final determination regarding who an unauthorized reseller is determined to be.

Warranty

1 Year Limited Warranty

To obtain service, contact LivePure® Customer Service at 888-855-5426. You will be responsible for insurance and freight or other transportation to our factory service center. We will return the freight prepaid. The **Ultrasonic Humidifier** should be properly packaged to avoid damage in transit since we will not be responsible for any such damage. Proof of purchase is required when requesting warranty service. The purchaser must present sales receipt or other document that establishes proof of purchase.

IN NO EVENT SHALL **LIVEPURE® COMPANY** BE LIABLE FOR DIRECT, INDIRECT, SPECIAL, CONSEQUENTIAL OR INCIDENTAL DAMAGES IN EXCESS OF THE PURCHASE PRICE OF THE **HUMIDIFIER**. YOUR SOLE REMEDY WILL BE REPAIR OR REPLACEMENT AS PROVIDED ABOVE. SOME AMERICAN STATES AND CANADIAN PROVINCES DO NOT ALLOW:

- LIMITATIONS ON HOW LONG AN IMPLIED WARRANTY LASTS;
- THE EXCLUSION OR LIMITATION OF DIRECT, INDIRECT, SPECIAL, INCIDENTAL, OR CONSEQUENTIAL DAMAGES; THE EXCLUSION OR INVALIDITY OF EXPRESS OR IMPLIED WARRANTIES IF THE USER CEASES TO OWN THE **HUMIDIFIER**;
- THE LIMITATION OF THE REMEDIES AND RECOURSES AVAILABLE TO THE PURCHASER; OR THE INVALIDITY OF AN EXPRESS WARRANTY WHEN A PRODUCT IDENTIFIED BY BRAND NAME IS NOT USED (UNLESS SPECIFIC CONDITIONS ARE FULFILLED); SO THE ABOVE LIMITATIONS OR EXCLUSIONS MAY NOT APPLY TO YOU. THIS WARRANTY GIVES YOU SPECIFIC LEGAL RIGHTS AND YOU MAY ALSO HAVE OTHER RIGHTS WHICH VARY FROM STATE TO STATE OR PROVINCE TO PROVINCE.

To request warranty service, visit www.livepureshop.com
or call (888) 855-5426